

Be sure to read and understand all instruction sheets completely before beginning assembly or installation.

- All assembly and installation work must be performed by qualified personnel, in accordance with all applicable national and local building and electrical codes.
- Be aware that the weight of some fixtures may exceed the strength rating of the 4" electrical junction box or other such hardware at your site. In all cases, it is the responsibility of the contractor to properly secure the fixture to the structure, and to provide adequate support for the fixture.
- Due to constant production improvements, details of the design, material or finish may change in any way that will not significantly alter installed appearance or reduce function or performance.

© East Taunton, MA 02718 (508) 977-9991

SKU: 1150 & 1151

INSTALLATION OF FIXTURE

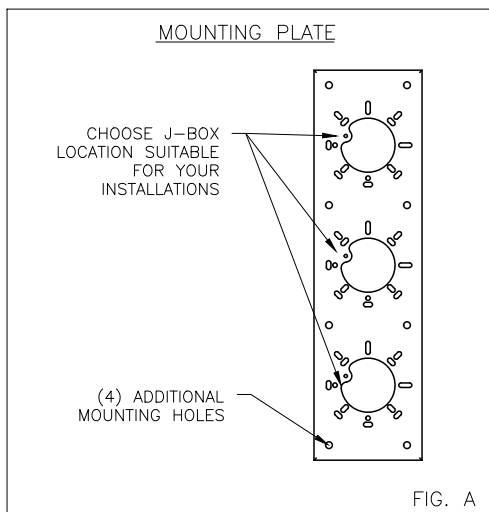

- 1) CHOOSE WHICH J-BOX LOCATION BEST SUITS YOUR INSTALL. (SEE FIG. A)
- 2) PULL ELECTRICAL FEED WIRES FROM J-BOX THRU THE CENTER HOLE OF THE MOUNTING PLATE.
- 3) ATTACH MOUNTING PLATE TO J-BOX AND THE WALL WITH (2) J-BOX SCREWS AND (4) SCREWS AND ANCHORS FOR THE WALL CONDITIONS FOR YOUR INSTALL.
- 4) APPLY SUITABLE CAULK ALONG THE EDGES OF THE MOUNTING PLATE WHERE IT MEETS THE WALL, ON BOTH SIDES AND THE TOP EDGE, TO PREVENT WATER ENTRY INTO THE ELECTRICAL JUNCTION BOX AREA. DO NOT APPLY CAULK TO THE BOTTOM EDGE: THIS WILL ALLOW WATER TO ESCAPE.
- 5) CONNECT THE ELECTRICAL WIRES FROM YOUR J-BOX TO THE WIRES FROM THE FIXTURE USING WIRE NUTS. (BLACK TO BLACK, WHITE TO WHITE, GREEN OR BARE GROUND TO GROUND)
- 6) ATTACH THE FIXTURE TO THE MOUNTING PLATE WITH THE (4) MOUNTING SCREWS PROVIDED. BE SURE THAT THE BLACK RUBBER WASHERS ARE USED UNDER THE SCREW HEADS. INSTALL AND TIGHTEN THE TOP (2) SCREWS FIRST, FOLLOWED BY THE BOTTOM SCREWS.
- 7) UNSCREW THE FINIAL ON THE TOP OF YOUR FIXTURE AND REMOVE THE COVER & SPACER.
- 8) PLACE THE 4 INDIVIDUAL GLASSES INTO THE FIXTURE AND SECURE BY BENDING OVER GLASS CLIPS IN THE FRAME.
- 9) SLIDE THE CANDLE SLEEVES OVER THE SOCKETS.
- 10) LAMP FIXTURE WITH THE REQUIRED NUMBER OF LAMPS AND WATTAGE PER FIXTURE.
- 11) PLACE THE COVER & SPACER BACK ON TOP OF YOUR FIXTURE AND SECURE IN PLACE WITH THE FINIAL.

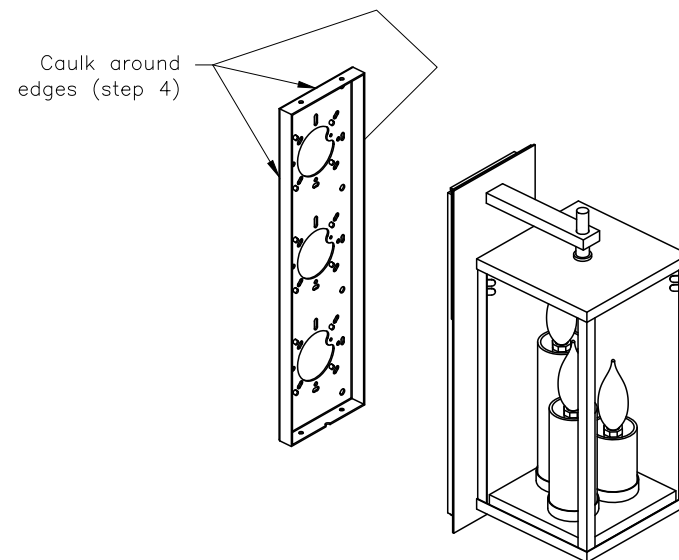
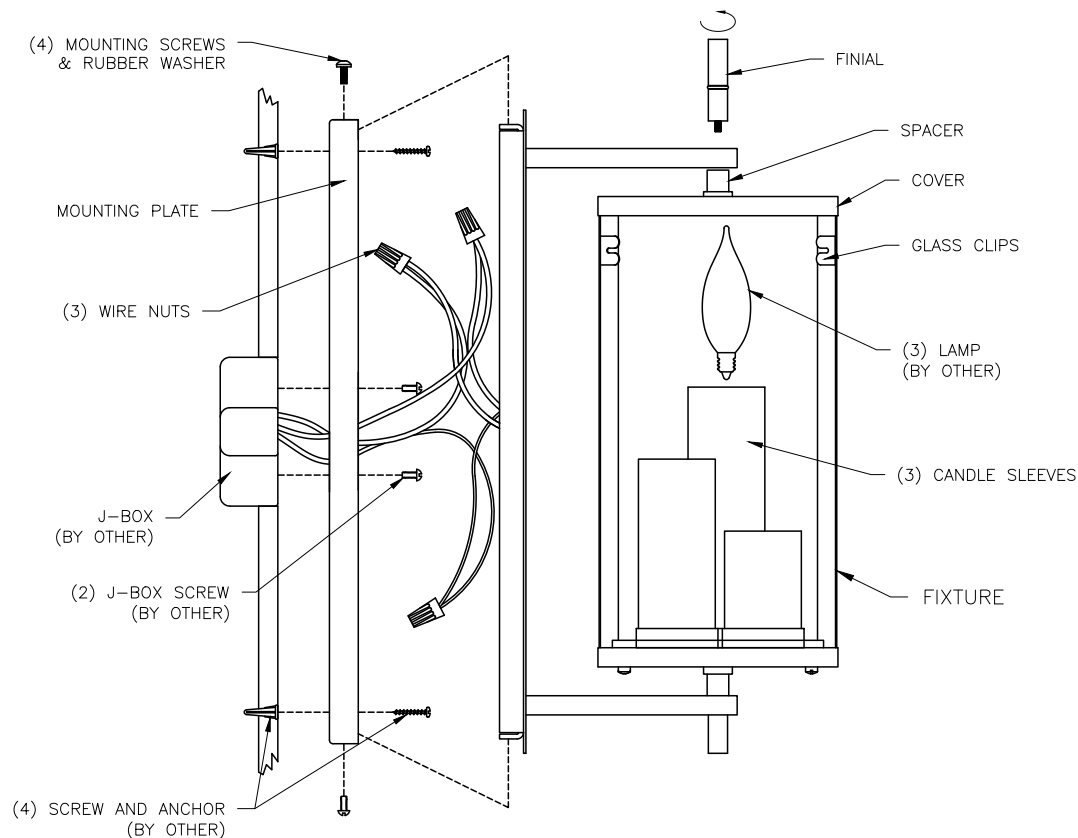

REV.	BY	DATE	DESCRIPTION
1	CAC	02/23/2022	INSTALL OF GLASS
INSTRUCTIONS			DRAWN BY: CAC
			SHEET #: SHEET 1 OF 1
BACK BAY - 1150 & 1151			
DATE: Dec 9, 2021		DWG: 210334-A-INST	