

Each Norwell light fixture has a mounting bar or plate to secure it to the electrical junction box. No matter what type of mounting bar/plate your fixture uses, installation requires three basic steps.

1. Attach the mounting bar/plate to the electrical junction box.
2. Connect the electrical wires from the junction box to the electrical wires from the fixture.  
(Black to Black, White to White and Green to Ground)
3. Secure the fixture to the mounting bar/plate.

# Norwell Lighting INSTRUCTIONS

5665

## INSTALLATION OF FIXTURE

FIG. A

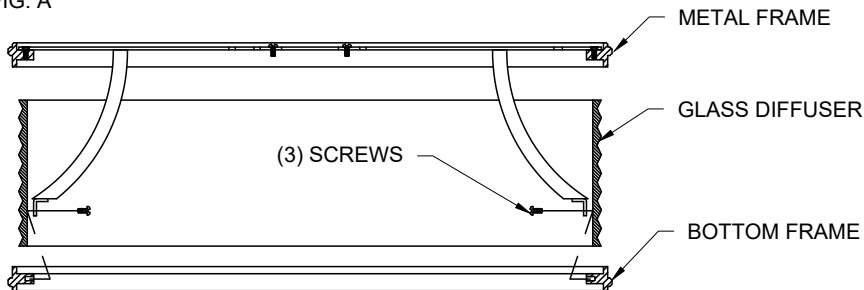

FIG. B

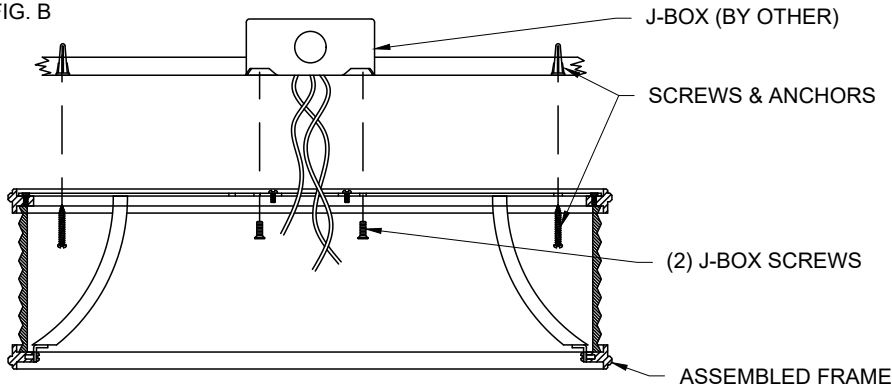
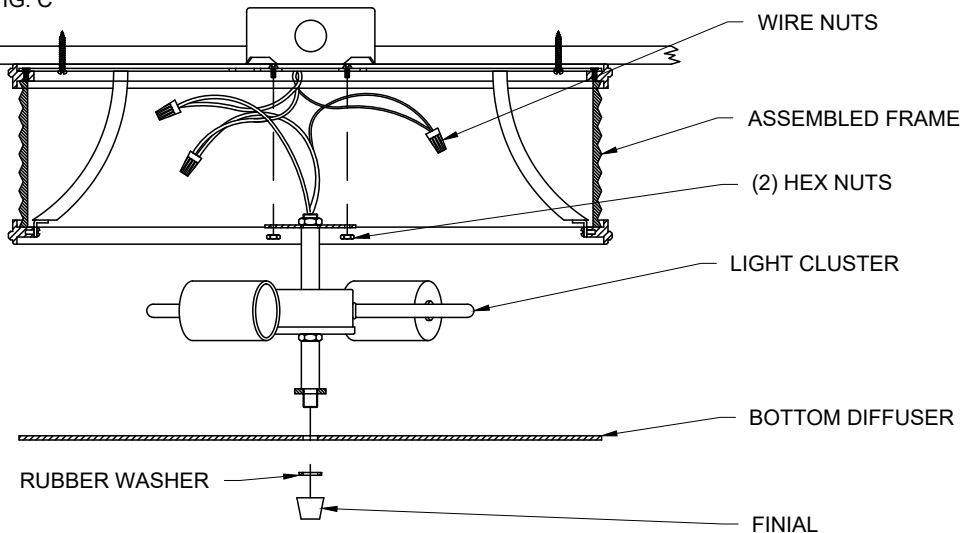

FIG. C



- 1) ASSEMBLY THE GLASS TO THE FRAME, BY SANDWICHING THE GLASS BETWEEN THE (2) FRAMES AND SECURING THE FRAME WITH (3) SCREWS. (SEE FIG. A)
- 2) PULL THE WIRES FROM THE J-BOX THROUGH THE CENTER HOLE IN THE FRAME AND ATTACH THE FRAME TO J-BOX AND CEILING WITH (2) J-BOX SCREWS AND SCREWS AND ANCHORS. (SEE FIG. B)
- 3) CONNECT THE ELECTRICAL WIRES FROM YOUR J-BOX TO THE WIRES FROM THE SOCKET ASSEMBLY USING WIRE NUTS. (BLACK TO BLACK, WHITE TO WHITE, GREEN TO GROUND) (SEE FIG. C)
- 4) ATTACH THE SOCKET ASSEMBLY TO THE FRAME, USING (2) HEX NUTS. BE SURE TO TUCK ALL WIRES BACK UP INSIDE J-BOX, TO PREVENT PINCHING OF WIRES WHEN TIGHTENING THE NUTS. (SEE FIG. C)
- 5) LAMP FIXTURE WITH THE REQUIRED NUMBER OF LAMPS AND WATTAGE PER FIXTURE.
- 6) ATTACH THE BOTTOM DIFFUSER TO THE FRAME WITH FINIAL. MAKE SURE TO PLACE A RUBBER WASHER BETWEEN FINAL AND BOTTOM DIFFUSER TO PREVENT THE FINAL FROM SCRATCHING THE BOTTOM DIFFUSER. (SEE FIG. C)

- Be sure to read and understand all instruction sheets completely before beginning assembly or installation.
- Be sure the power is turned off by either by removing the fuse or closing the circuit breaker.
- All assembly and installation work must be in accordance with National, State and Local electrical codes. We strongly advise using a licensed electrician.
- Be aware that the weight of some fixtures may exceed the strength rating of the 4" electrical junction box or other such hardware at your site. In all cases, it is the responsibility of the contractor to properly secure the fixture to the structure, and to provide adequate support for the fixture.
- Due to constant production improvements, details of the design, material or finish may change in any way that will not significantly alter installed appearance or reduce function or performance.