

Each Norwell light fixture has a mounting bar or plate to secure it to the electrical junction box. No matter what type of mounting bar/plate your fixture uses, installation requires three basic steps.

1. Attach the mounting bar/plate to the electrical junction box.
2. Connect the electrical wires from the junction box to the electrical wires from the fixture. (Black to Black, White to White and Green to Ground).
3. Secure the fixture to the mounting bar/plate.

# Norwell Lighting INSTRUCTIONS 6512

## INSTALLATION OF FIXTURE

1. PLACE THE MOUNTING PLATE OVER THE JUNCTION BOX. MARK TWO POINTS ON THE WALL AT THE CENTER OF KEYHOLE ON THE MOUNTING PLATE.
2. DRILL TWO HOLES AT THE MARKED POINTS AND INSERT THE WALL ANCHORS.
3. PLACE THE MOUNTING PLATE OVER THE JUNCTION BOX AND SECURE IT WITH JUNCTION BOX SCREWS. INSERT AND TIGHTEN THE ANCHOR SCREWS INTO THE WALL ANCHORS UNTIL SNUG.
4. CONNECT THE ELECTRICAL WIRES FROM YOUR JUNCTION BOX TO THE WIRES FROM THE CANOPY USING WIRE NUTS. (BLACK TO BLACK, WHITE TO WHITE, GREEN TO GROUND)
5. INSTALL BACKPLATE ONTO THE MOUNTING PLATE, AND SECURE WITH THE MOUNTING SCREWS.
6. INSTALL THE BULB (NOT INCLUDED) INTO THE SOCKET.
7. SLIP THE GLASS OVER THE SOCKET AND THREAD THE GLASS INTO THE GLASS HOLDER AND HAND TIGHTEN UNTIL SNUG.

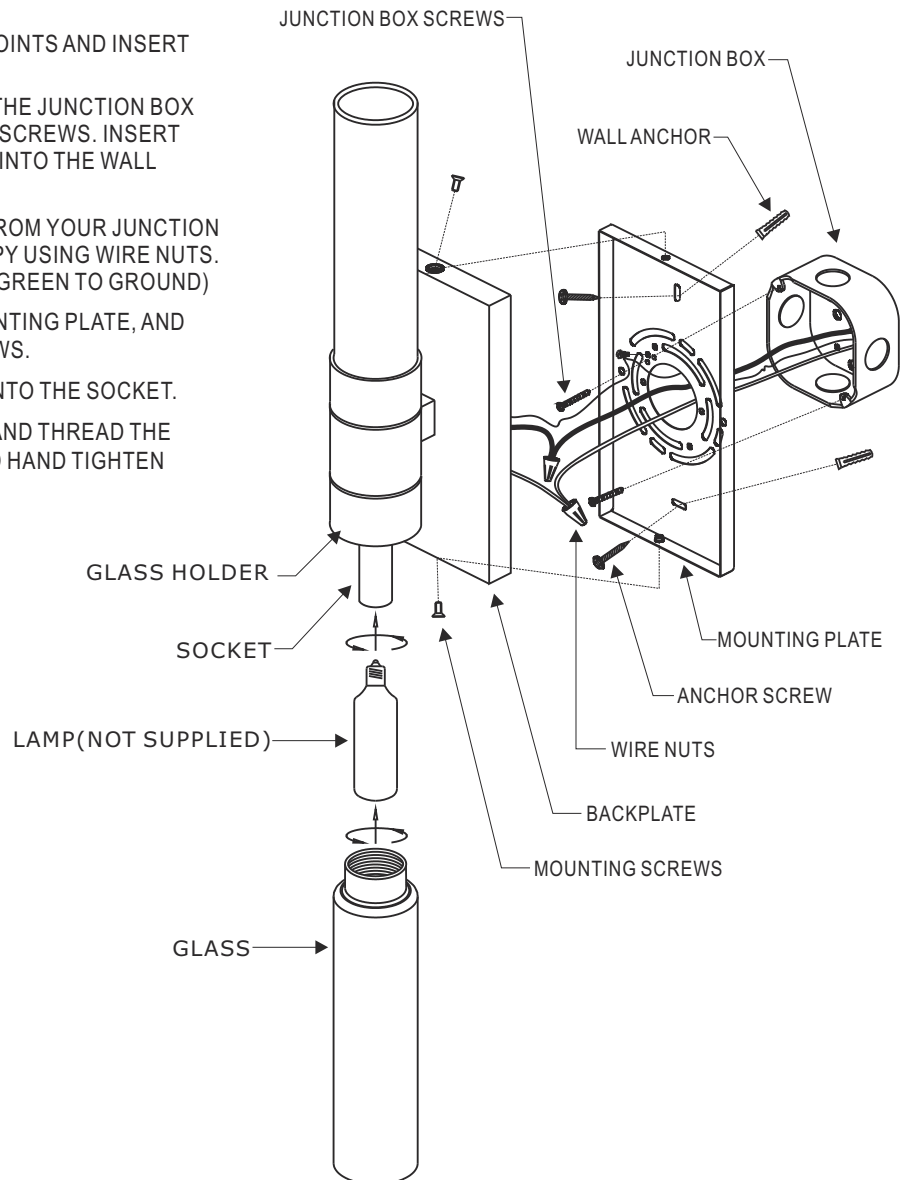

**Note: The fixture can be installed either vertically or horizontally.**

- Be sure to read and understand all instruction sheets completely before beginning assembly or installation.
- Be sure the power is turned off by removing the fuse or closing the circuit breaker.
- All assembly and installation work must be in accordance with National, State and Local electrical codes. We strongly advise using a licensed electrician.
- Be aware that the weight of some fixtures may exceed the strength rating of the 4" electrical junction box or other such hardware at your site. In all cases, it is the responsibility of the contractor to properly secure the fixture to the structure, and to provide adequate support for the fixture.
- Due to constant production improvements, details of the design, material or finish may change in any way that will not significantly alter installed appearance or reduce function or performance.