

Each Norwell light fixture has a mounting bar or plate to secure it to the electrical junction box. No matter what type of mounting bar/plate your fixture uses, installation requires three basic steps.

Norwell Lighting

INSTRUCTIONS

SKU# 6520 & 6521

1. Attach the mounting bar/plate to the electrical junction box.
2. Connect the electrical wires from the junction box to the electrical wires from the fixture.
(Black to Black, White to White and Green to Ground)
3. Secure the fixture to the mounting bar/plate.

INSTALLATION OF FIXTURE

- 1) FEED THE WIRES FROM THE FIXTURE THROUGH THE CENTER STEM AND SCREW THE STEM INTO THE CENTER HUB. (CENTER STEM IS LONGEST STEM SUPPLIED WITH FIXTURE)
- 2) ADD EXTENSIONS RODS TO THE CENTER STEM TO ACHIEVE YOUR DESIRED OVERALL HEIGHT. (2 - 12" & 1 - 6" EXTENSION RODS ARE PROVIDED)
- 3) SCREW THE HANG STRAIGHT AND CANOPY ON THE FINAL STEM ASSEMBLY, WHILE FEEDING YOUR WIRE THROUGH THE CENTER OF THE HANG STRAIGHT.
- 4) ATTACH MOUNTING BAR TO J-BOX WITH 2 SCREWS.
- 5) CONNECT THE ELECTRICAL WIRES FROM YOUR J-BOX TO THE WIRES FROM THE FIXTURE USING WIRE NUTS. (BLACK TO BLACK, WHITE TO WHITE, GREEN TO GROUND)
- 6) ATTACH THE FIXTURE TO THE MOUNTING BAR, USING THE (3) MOUNTING SCREWS PROVIDED.
- 7) LAMP FIXTURE WITH THE REQUIRED NUMBER OF LAMPS AND WATTAGE PER FIXTURE.

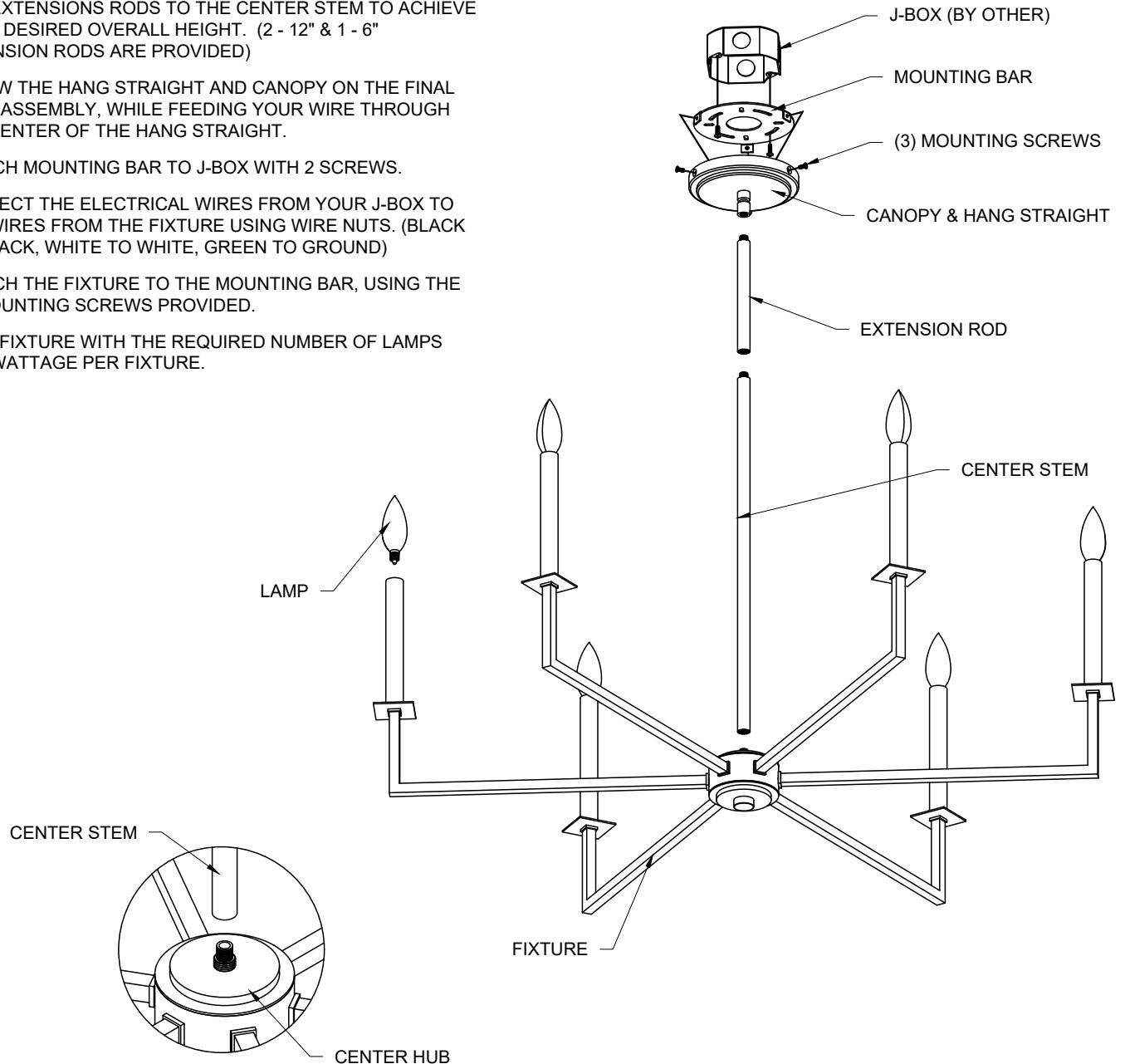

- Be sure to read and understand all instruction sheets completely before beginning assembly or installation.
- All assembly and installation work must be performed by qualified personnel, in accordance with all applicable national and local building and electrical codes.
- Be aware that the weight of some fixtures may exceed the strength rating of the 4" electrical junction box or other such hardware at your site. In all cases, it is the responsibility of the contractor to properly secure the fixture to the structure, and to provide adequate support for the fixture.
- Due to constant production improvements, details of the design, material or finish may change in any way that will not significantly alter installed appearance or reduce function or performance.