

Each Norwell light fixture has a mounting bar or plate to secure it to the electrical junction box. No matter what type of mounting bar/plate your fixture uses, installation requires three basic steps.

Norwell Lighting INSTRUCTIONS

SKU#: 6525 & 6526

PAGE: 1 OF 2

1. Attach the mounting bar/plate to the electrical junction box.
2. Connect the electrical wires from the junction box to the electrical wires from the fixture.
(Black to Black, White to White and Green to Ground)
3. Secure the fixture to the mounting bar/plate.

INSTALLATION OF FIXTURE

- 1) DETERMINE YOUR DESIRED OVERALL HEIGHT.
- 2) ATTACHED THE CANOPY OR LOOP AND CHAIN TO THE CENTER HUB. FEED THE ELECTRICAL WIRES THROUGH THE CENTER HOLE OF EACH COMPONENT. (OPTION A OR OPTION B)
- 3) HOOK THE 2 REMAINING ARMS FROM YOUR FIXTURE TO THE LOOPS ON THE CENTER HUB.
- 4) ATTACH MOUNTING BAR TO J-BOX WITH 2 SCREWS.
- 5) CONNECT THE ELECTRICAL WIRES FROM YOUR J-BOX TO THE WIRES FROM THE CANOPY WITH WIRE NUTS. (BLACK TO BLACK, WHITE TO WHITE, GREEN TO GROUND)
- 6) ATTACH THE CANOPY TO THE MOUNTING BAR, USING THE (3) MOUNTING SCREWS.

CONTINUE TO PAGE 2

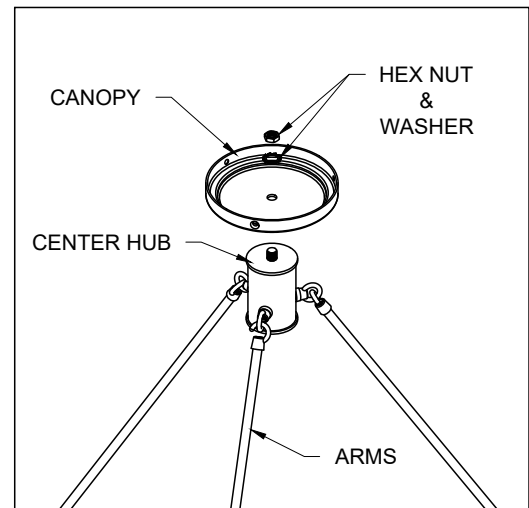

OPTION A

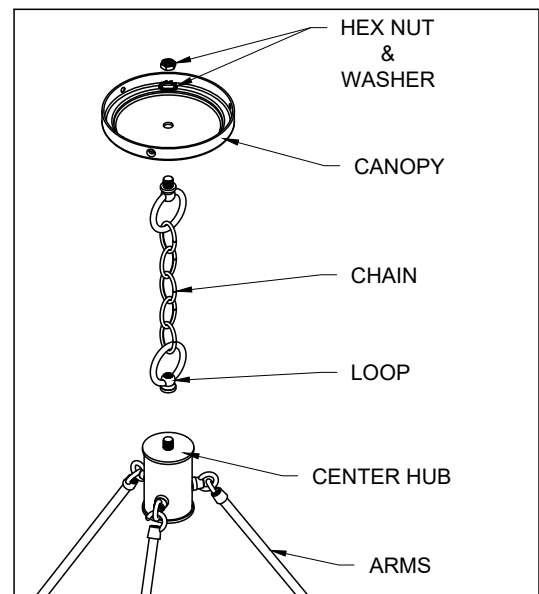
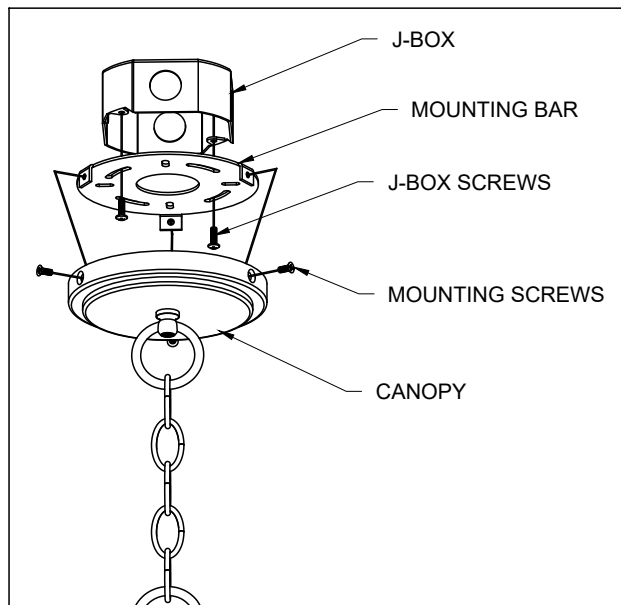

OPTION B

PAGE 1

- Be sure to read and understand all instruction sheets completely before beginning assembly or installation.
- Be sure the power is turned off by either by removing the fuse or closing the circuit breaker.
- All assembly and installation work must be in accordance with National, State and Local electrical codes. We strongly advise using a licensed electrician.
- Be aware that the weight of some fixtures may exceed the strength rating of the 4" electrical junction box or other such hardware at your site. In all cases, it is the responsibility of the contractor to properly secure the fixture to the structure, and to provide adequate support for the fixture.
- Due to constant production improvements, details of the design, material or finish may change in any way that will not significantly alter installed appearance or reduce function or performance.

Each Norwell light fixture has a mounting bar or plate to secure it to the electrical junction box. No matter what type of mounting bar/plate your fixture uses, installation requires three basic steps.

Norwell Lighting

INSTRUCTIONS

SKU#: 6525 & 6526

PAGE: 2 OF 2

1. Attach the mounting bar/plate to the electrical junction box.
2. Connect the electrical wires from the junction box to the electrical wires from the fixture.
(Black to Black, White to White and Green to Ground)
3. Secure the fixture to the mounting bar/plate.

INSTALLATION OF FIXTURE

THIS IS PAGE 2, IF YOU HAVE NOT COMPLETED STEPS ON PAGE 1. PLEASE GO BACK TO PAGE 1 AND FOLLOW STEPS 1-6. IF YOU HAVE PURCHASED CANDLE OPTION, FOLLOW STEPS 1 & 2. IF YOU HAVE PURCHASED MATTE OPAL OPTION, FOLLOW STEPS 3 & 4.

- 1) PLACE THE CANDLE SLEEVES OVER EACH SOCKET.
- 2) LAMP FIXTURE WITH THE REQUIRED NUMBER OF LAMPS AND WATTAGE PER FIXTURE.
- 3) LAMP FIXTURE WITH THE REQUIRED NUMBER OF LAMPS AND WATTAGE PER FIXTURE.
- 4) PLACE GLASS DIFFUSER OVER LAMP, INTO THE METAL CUP

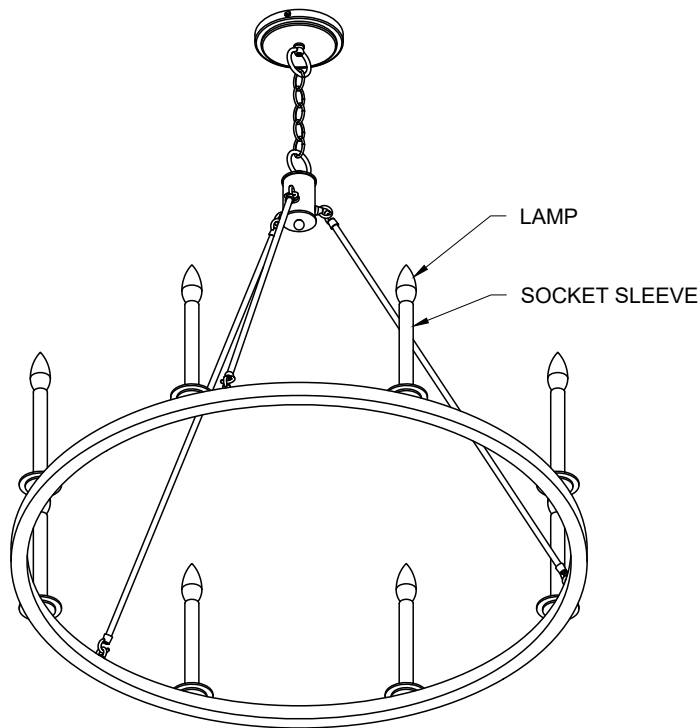

CANDLE OPTION

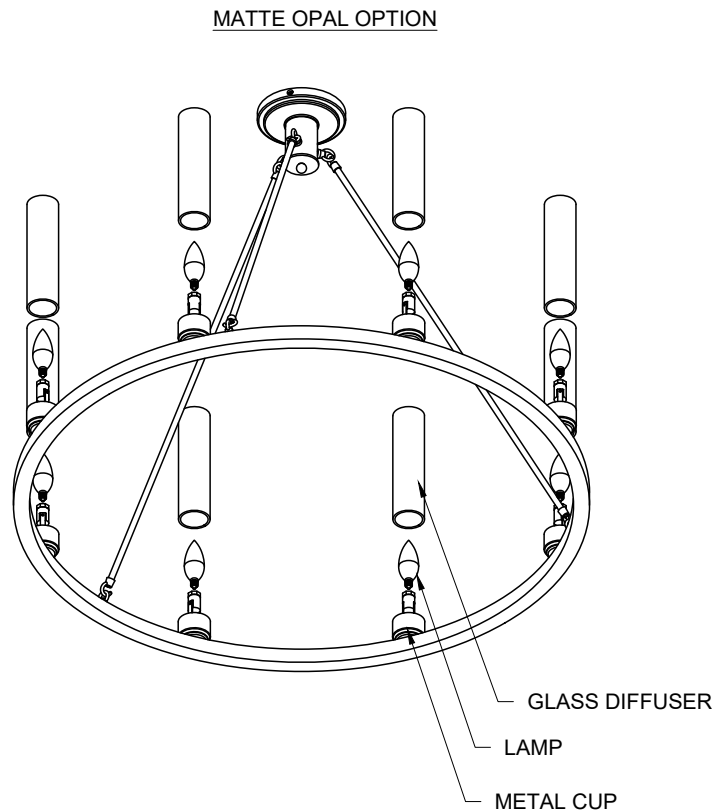

PAGE 2

- Be sure to read and understand all instruction sheets completely before beginning assembly or installation.
 - Be sure the power is turned off by either by removing the fuse or closing the circuit breaker.
 - All assembly and installation work must be in accordance with National, State and Local electrical codes. We strongly advise using a licensed electrician.
 - Be aware that the weight of some fixtures may exceed the strength rating of the 4" electrical junction box or other such hardware at your site. In all cases, it is the responsibility of the contractor to properly secure the fixture to the structure, and to provide adequate support for the fixture.
 - Due to constant production improvements, details of the design, material or finish may change in any way that will not significantly alter installed appearance or reduce function or performance.
- © Norwell Manufacturing Company Inc. - East Taunton, MA 02718 Tel: 508-977-9991 www.Norwellinc.com