

Each Norwell light fixture has a mounting bar or plate to secure it to the electrical junction box. No matter what type of mounting bar/plate your fixture uses, installation requires three basic steps.

1. Attach the mounting bar/plate to the electrical junction box.
2. Connect the electrical wires from the junction box to the electrical wires from the fixture.
(Black to Smooth, White to Ribbed and Green to Ground).
3. Secure the fixture to the mounting bar/plate.

Norwell Lighting INSTRUCTIONS 6671

INSTALLATION OF FIXTURE

1. SLIP THE ROD-1 ALONG WIRE AND THREAD IT INTO THE BOTTOM OF THE BACKPLATE.
2. SLIP THE ROD-2 ALONG WIRE AND THREAD IT INTO THE BOTTOM OF THE ROD-1, THEN TIGHTEN THE SCREW.
3. POSITION THE MOUNTING PLATE THROUGH THE FIXING HOLES ONTO THE WALL AND MAKE MARKS, DRILL PILOT HOLES FOR WOOD SCREWS INTO THE WALL, THEN INSERT THE PLASTIC ANCHOR INTO THE HOLES.
4. ATTACH THE MOUNTING PLATE TO WALL WITH 2 WOOD SCREWS.
5. INSTALL BACKPLATE ONTO THE MOUNTING PLATE, AND SECURE WITH THE MOUNTING SCREWS.
6. SLIP THE GLASS OVER THE SOCKET, THEN SECURE IT WITH THE PLASTIC WASHER AND BALL SCREWS.
7. PUT THE FABRIC SHADE ONTO THE METAL RING, AND SECURE IT WITH THE SCREWS.
8. INSTALL THE BULB (NOT INCLUDED) INTO THE SOCKET.

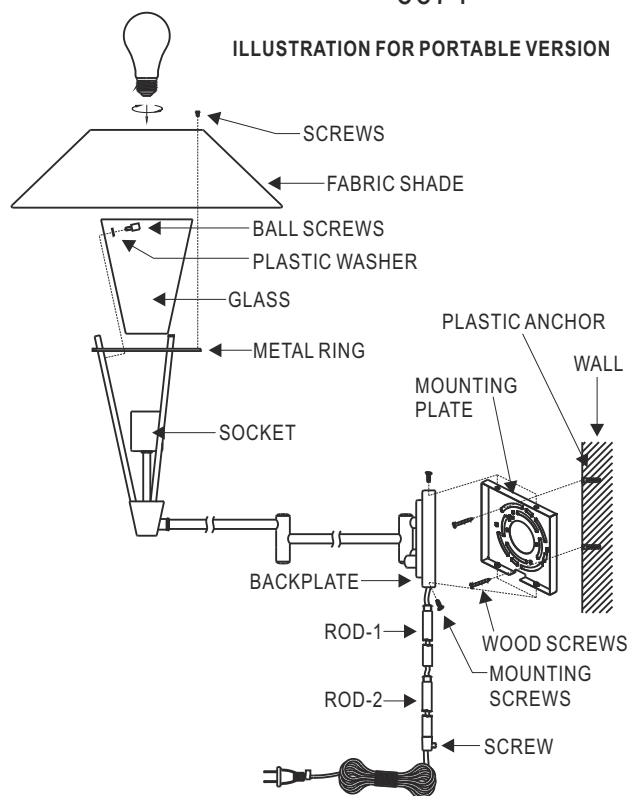

INSTALLATION OF FIXTURE

1. PLEASE CUT OFF THE PLUG WIRE THEN REMOVE THE PLUG WIRE. (THE LENGTH OF THE FIXTURE WIRE IS NOT LESS THAN 6").
2. INSTALL PLASTIC CAP INTO HOLE OF BACKPLATE BOTTOM.
3. ATTACH THE MOUNTING PLATE TO JUNCTION BOX WITH 2 JUNCTION BOX SCREWS.
4. CONNECT THE ELECTRICAL WIRES FROM YOUR JUNCTION BOX TO THE WIRES FROM THE BACKPLATE USING WIRE NUTS. (BLACK TO SMOOTH, WHITE TO RIBBED, GREEN TO GROUND)
5. INSTALL BACKPLATE ONTO THE MOUNTING PLATE, AND SECURE WITH THE MOUNTING SCREWS.
6. SLIP THE GLASS OVER THE SOCKET, THEN SECURE IT WITH THE PLASTIC WASHER AND BALL SCREWS.
7. PUT THE FABRIC SHADE ONTO THE METAL RING, AND SECURE IT WITH THE SCREWS.
8. INSTALL THE BULB (NOT INCLUDED) INTO THE SOCKET.

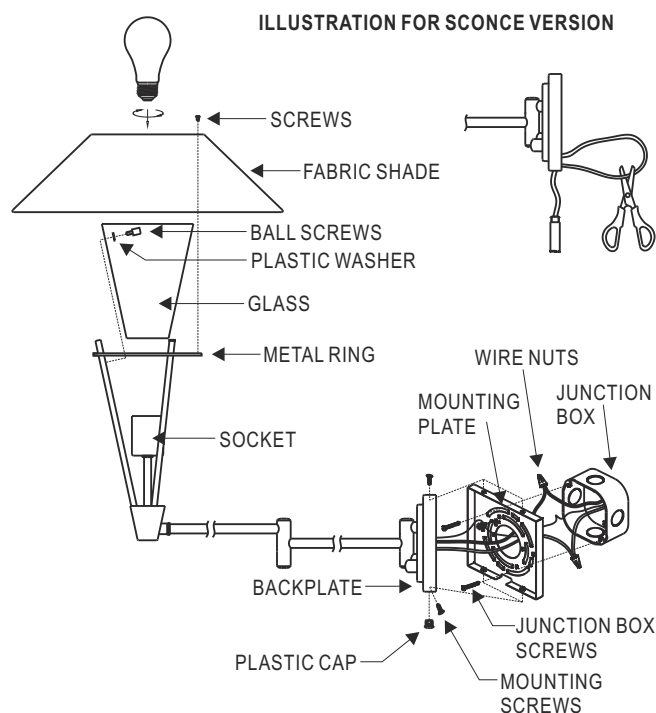

• Be sure to read and understand all instruction sheets completely before beginning assembly or installation.

• Be sure the power is turned off by removing the fuse or closing the circuit breaker.

• All assembly and installation work must be in accordance with National, State and Local electrical codes. We strongly advise using a licensed electrician.

• Be aware that the weight of some fixtures may exceed the strength rating of the 4" electrical junction box or other such hardware at your site. In all cases, it is the responsibility of the contractor to properly secure the fixture to the structure, and to provide adequate support for the fixture.

• Due to constant production improvements, details of the design, material or finish may change in any way that will not significantly alter installed appearance or reduce function or performance.