

Be sure to read and understand all instruction sheets completely before beginning assembly or installation.

All assembly and installation work must be performed by qualified personnel, in accordance with all applicable national and local building and electrical codes.

• Be aware that the weight of some fixtures may exceed the strength rating of the 4" electrical junction box or other such hardware at your site. In all cases, it is the responsibility of the contractor to properly secure the fixture to the structure, and to provide adequate support for the fixture.

• Due to constant production improvements, details of the design, material or finish may change in any way that will not significantly alter installed appearance or reduce function or performance.

© East Taunton, MA D2718 (5D8) 977-9991

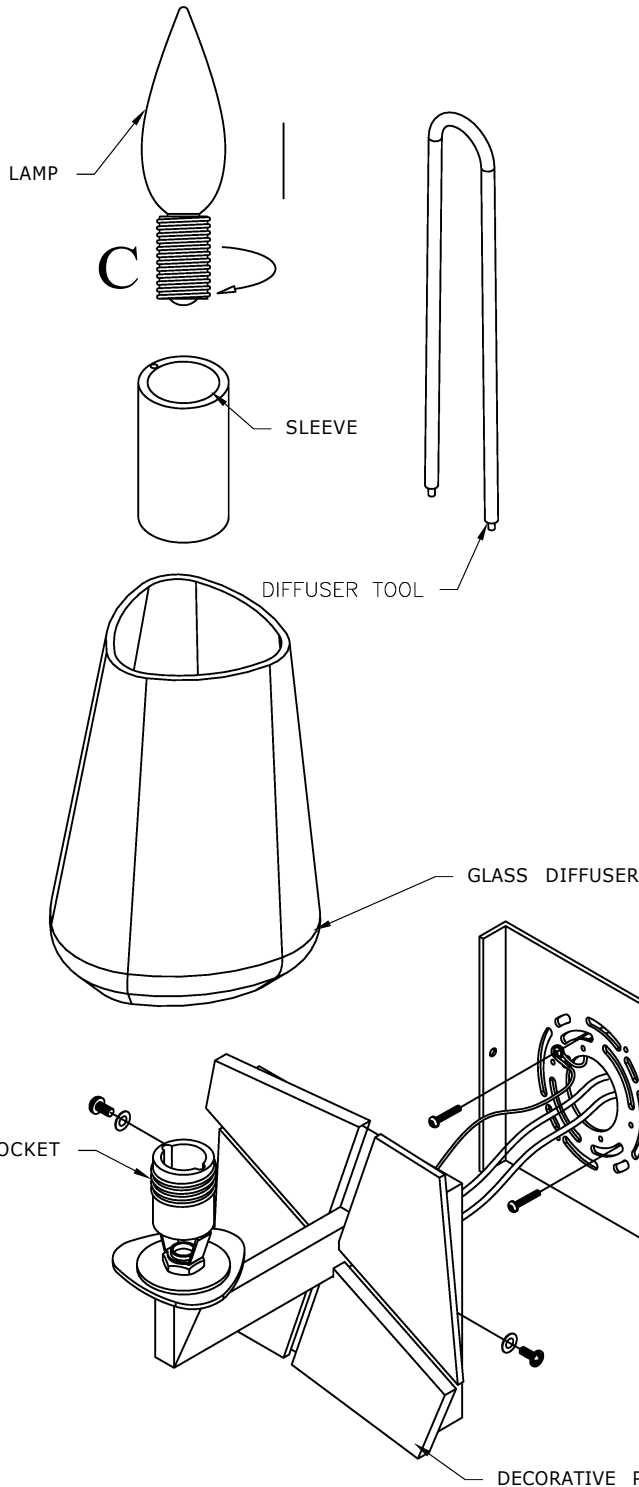

1) Turn power off! Pull the wires out of the junction box and feed them through the center hole in the mounting plate.

Attach the mounting plate to the junction box with the screws provided so your fixture mounts vertically perpendicular to the ceiling.

2) Connect the light fixture wires to the wires in the junction box.

Wire black or brown to line voltage, white or blue to neutral, and attach the green or bare wire to the green ground screw provided on the mounting plate. Use wire nuts on the connections and leave no bare wire exposed (excepting the green). Tuck the wires inside the junction box.

3) Secure the light fixture to the mounting plate by lining up the holes on the decorative cover with the threaded holes on the mounting plate and screwing in the screws provided. Make sure to fasten securely.

4) Screw in the lamp and seat the diffuser on the socket tray. Put the sleeve on the socket and thread the sleeve down (using the diffuser tool) until it holds the diffuser in place. Do not over tighten.

5) Turn your power back on and you have completed the installation process.

Norwell Lighting

REV.	BY	DATE	DESCRIPTION
INSTRUCTIONS			SHEET # D.B. BY SHEET 1 OF 1
8161-LILYPAD			
DA10/14/2019	DWG.	8161-LILYPAD-INST	
FILENAME 8161-LILYPAD INSTALLATION			